

**580N W/TIER 4 ENGINE
CASE BACKHOE**

INSTALLATION INSTRUCTIONS



HAMMOND AIR CONDITIONING LTD
INGERSOLL, ONT.
1-800-267-2665

Evaporator assembly: The evaporator coil is mounted in the factory location above the headliner. It slides in next to the heater coil with its fittings pointing out to the right side of the cab. ****NOTE: Clean hands before removing the headliner****

Steps:

1. Remove the covers from the side columns on both sides of the cab just behind the doors. Remove the round black plastic retaining plugs with a flat screw driver or special removal tool. Pull the covers out from the wall and disconnect the speaker wires. Remove the covers from the machine.
2. Remove the front window shade assembly and the rear view mirror using a philips screw driver.
3. Remove the air filter assembly, located just forward of the inside air/intake, by removing the two thumb screws. Slide the filter assembly out and remove from the cab.

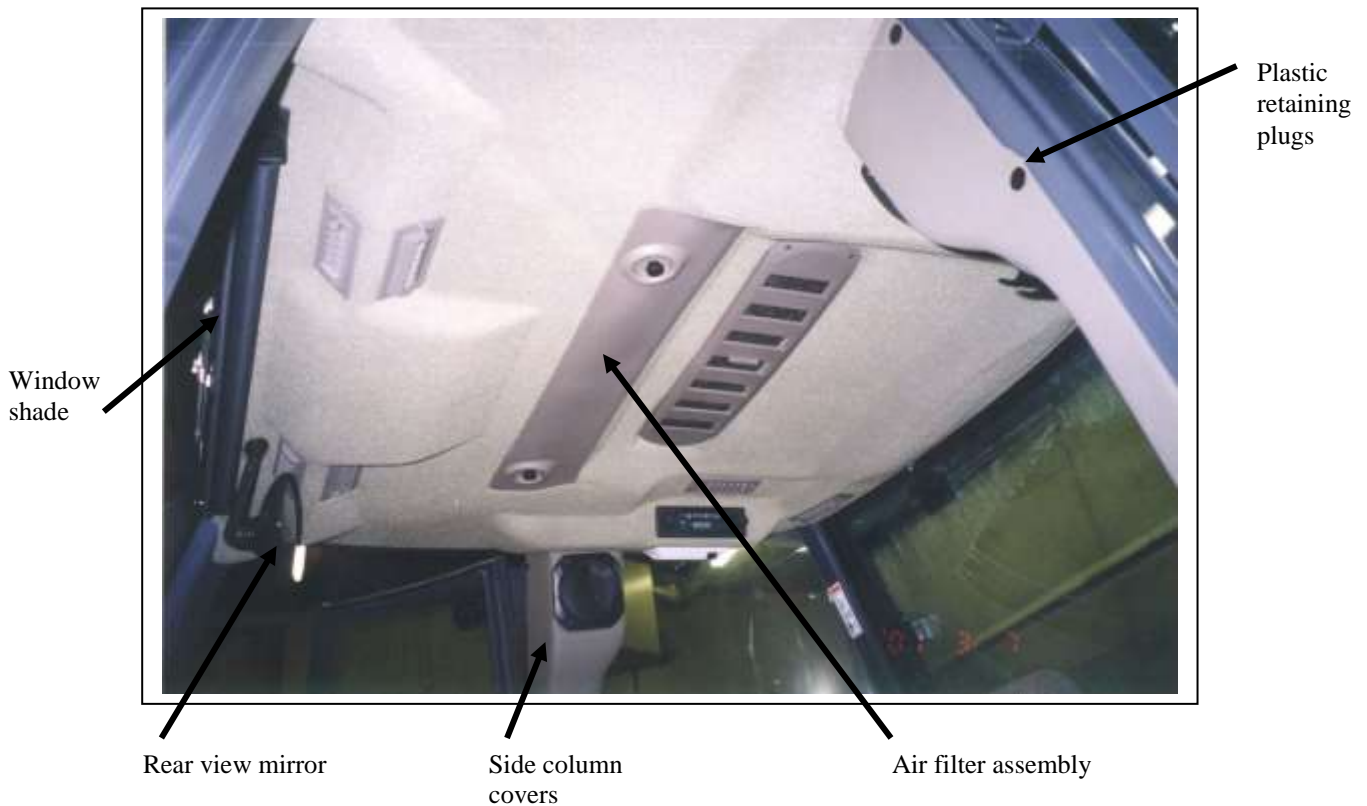

4. Remove the remaining Philips screws that secure the headliner along the front of the cab.
5. Pull the headliner out of its retaining channels all the way around the cab and let it sit down on the seat. Disconnect the wiring for the radio and interior light from the backside of the headliner. Remove the headliner from the cab and set aside in a clean area.

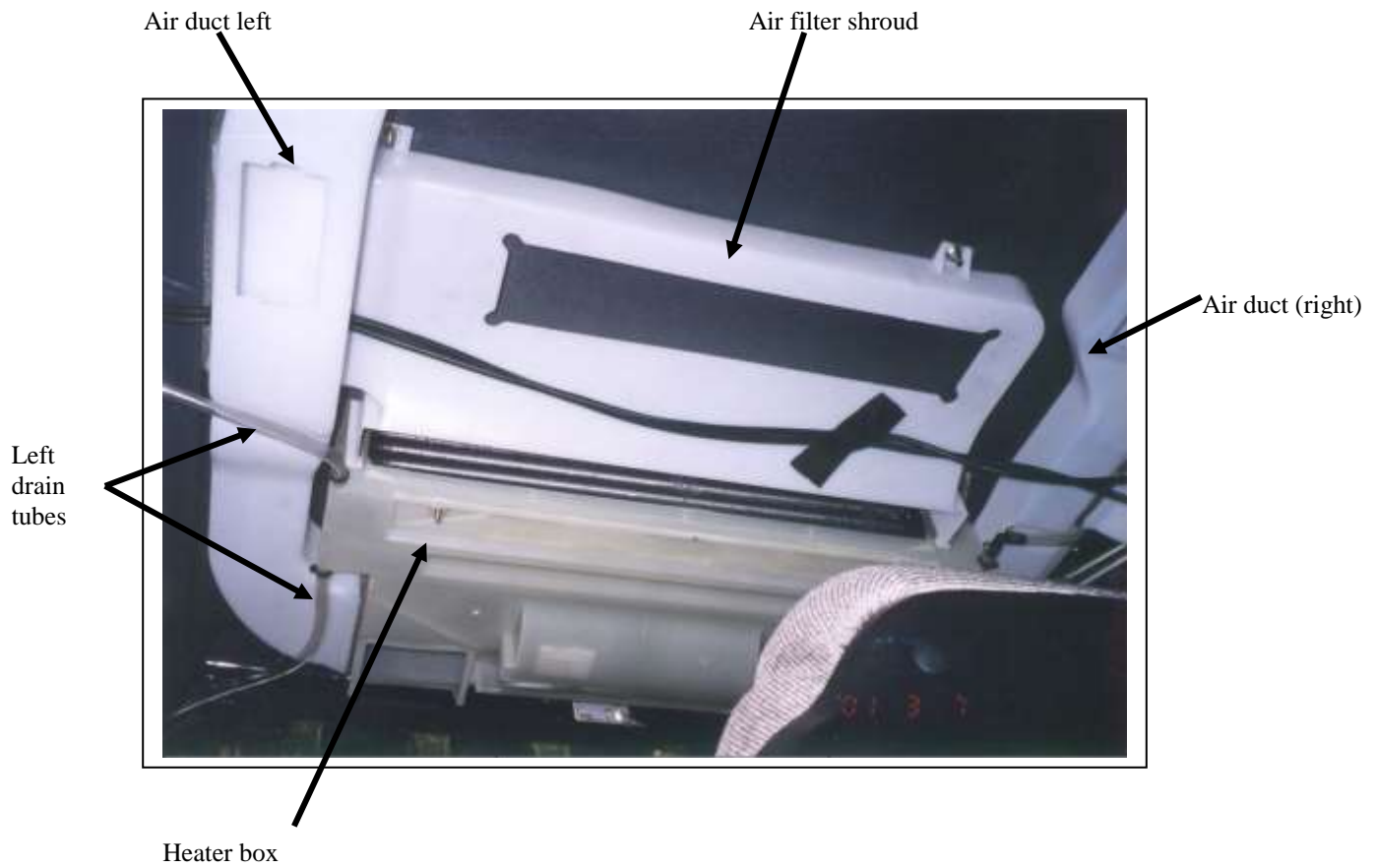

6. Remove the right side lower louver air duct by cutting the tie wraps holding it in place and removing the two round flex ducts on the lower end.



Right side
column

Heater lines

7. Remove the side air ducts from both sides of the machine. The retaining bolt is located inside the rear louver hole. The fronts just pop out of the holes. Remove the plastic air filter shroud from behind the heater box by removing the two retaining nuts and sliding it out of its slots on the heater box.
8. Loosen the front two nuts on the heater box but leave the nuts on the ends of the studs. Remove the rear two nuts on the heater box completely.

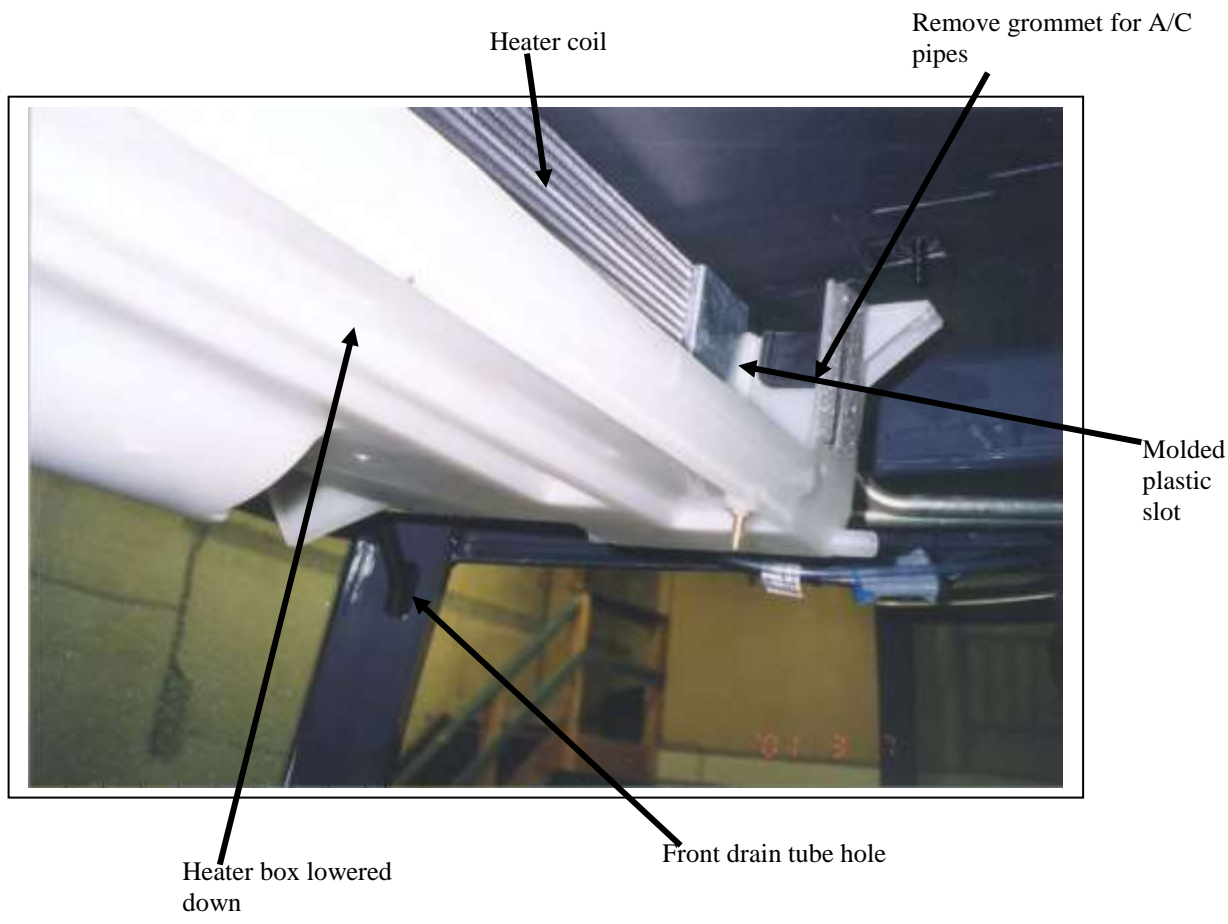

9. Pull the heater box down from the roof of the cab and remove the black grommet from the right side of the evaporator area of the box.

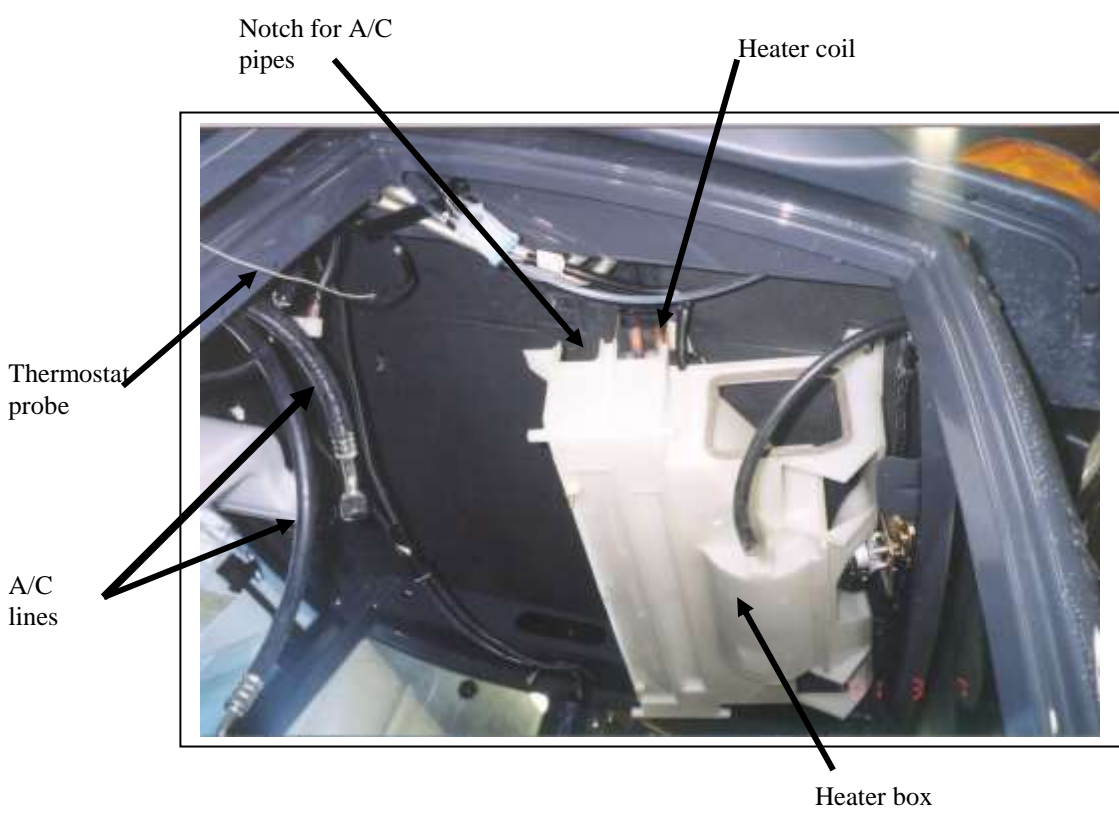

10. Remove the storage compartment from just below the gauge cluster on the right side of the cab. Unscrew the electrical console, including the gauge cluster and lift it out of its mount hole. Pop the plastic plug from the thermostat mount location on the front lower corner of the electrical console. Mount the rotary 72" thermostat in the hole. Run the 72" probe up the right column along with the heater hoses and over to the evaporator coil area.



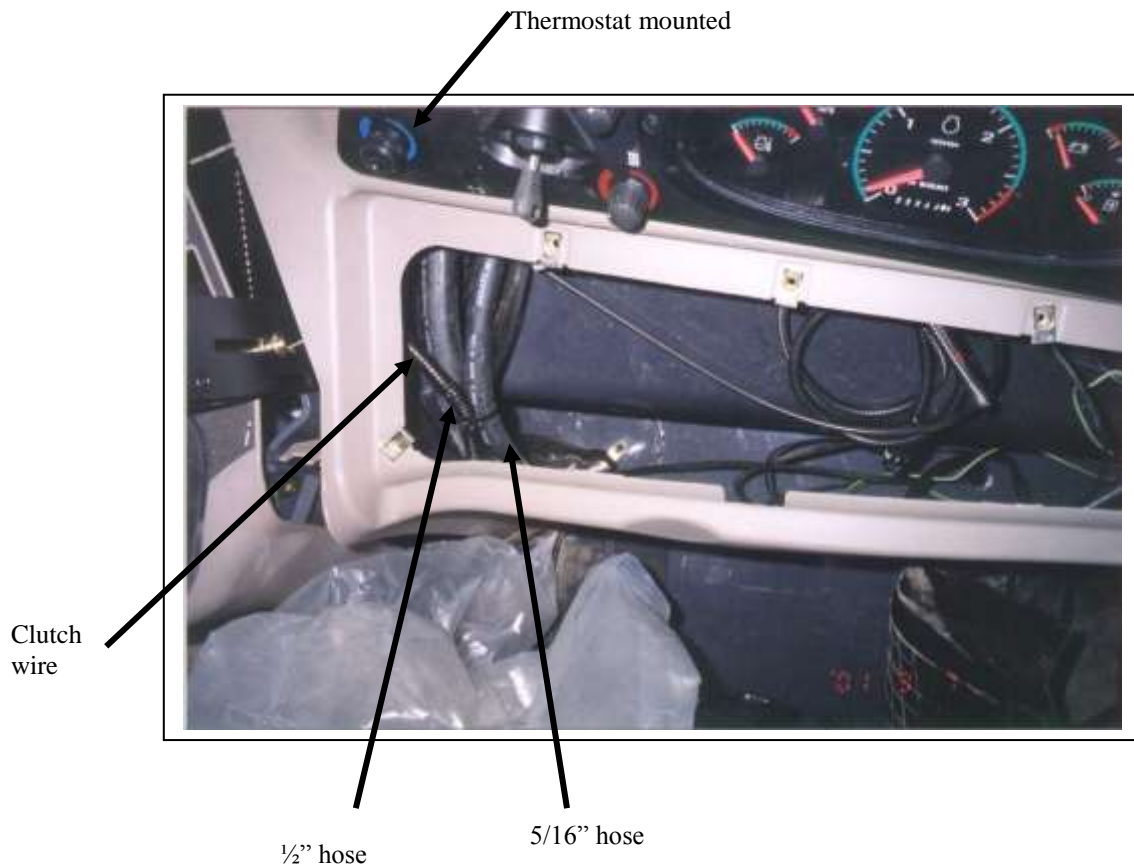

11. Slide the evaporator coil in place with the fitting end of the right and the coil flanges towards the heater coil. Insert the coil flanges into the molded plastic slots along with the heater coil flanges. Before lifting the box back into place, insert the 72" thermostat probe into the coil between the front two rows of tubes. From the top of the coil down about 4". The probe should be about two to three inches in from the fitting end of the coil. This should be about the coldest part of the coil. When testing it may be necessary to adjust the thermostat settings to avoid coil freeze up, refer to the thermostat setting procedures at the back of the instructions.

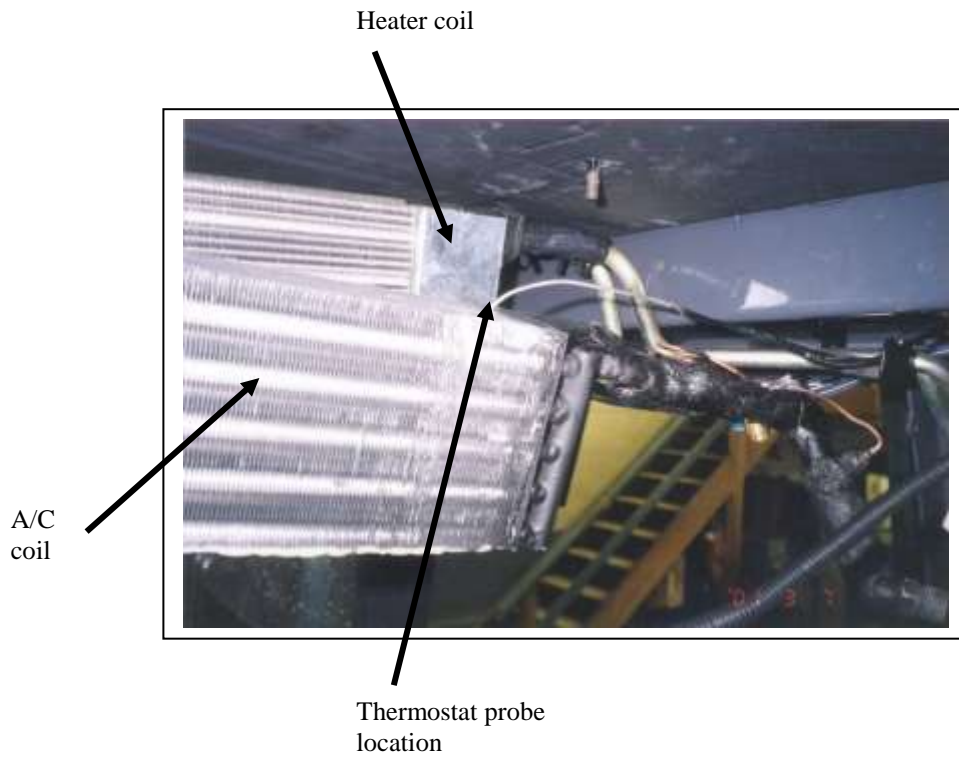

12. Bolt the heater coil back into place on the ceiling of the cab. Ensure that the coil flanges are seated in the molded plastic slots.

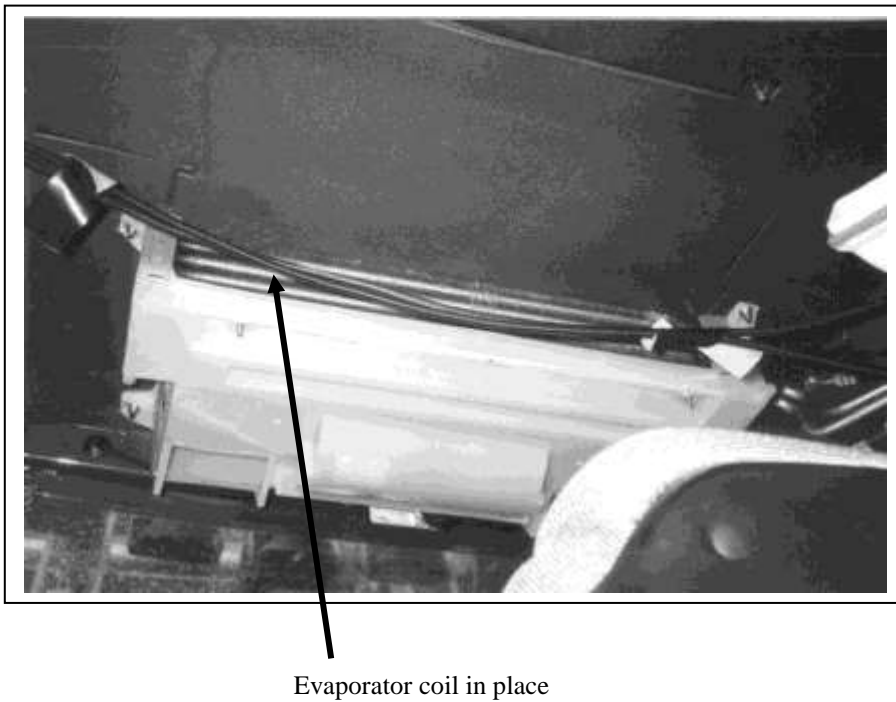

13. Once the evaporator coil is in place, it is necessary to connect the 5/16" and 1/2" A/C lines before re-installing the plastic ducts.
14. Remove the cover from the front bucket control lever and the parking brake handle. Lift the cover up to gain access to the area that the heater hoses enter the cab.
15. Remove the two part black plastic retaining clamp from around the heater hoses at the floor of the cab. Cut off the unused half of the clamp and re-install it around the heater lines. This leaves an opening large enough to bring both A/C hoses and the clutch wire into the cab.
16. Working from underneath the cab, feed the long 5/16" line with the 45° fitting on it, the 1/2" line with the 45° fitting on it and the clutch wire in loom up into the cab. Route the two A/C lines up over the right wheel well and back behind the electrical console to the right side column. Stop the clutch wire at the thermostat area to be connected to the thermostat. Run the two hoses up the right column beside the heater hoses and connect them to the evaporator fittings. Use the supplied "O" rings, oil all contact surfaces with PAG oil, and tighten the fittings. The 5/16" hose should be closest to the heater lines and the 1/2" hose to the rear of it. Ensure that both hoses pass between the roof beam and the black metal clamp. To do this it will be easier to unbolt the rear of the clamp until the hoses are all installed.

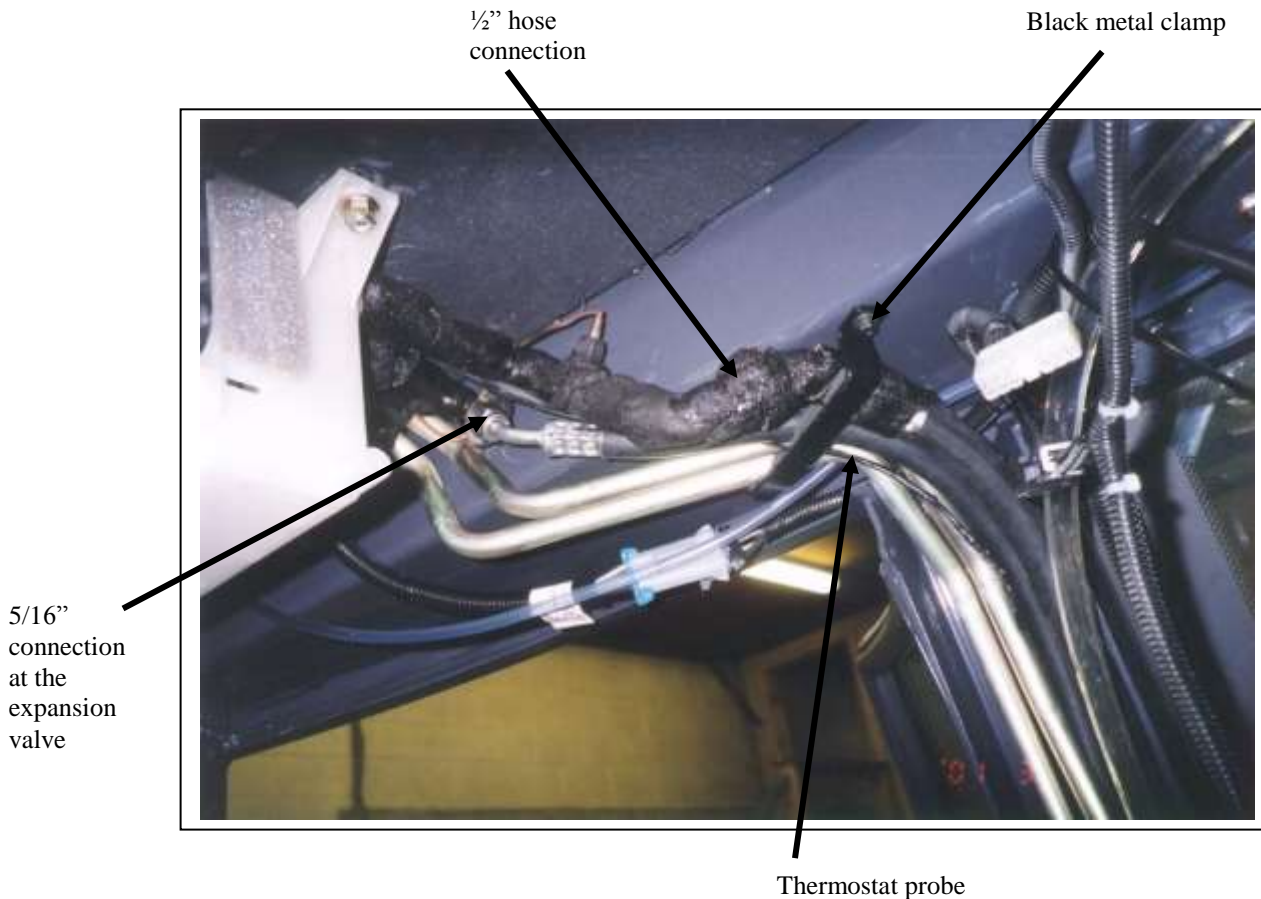

17. Keep the hoses as tight to the heater lines and the roof beams as possible. This will be important for re-installing the right lower louver air duct. When the rest of the system has been installed and leak checked, the ½” fitting can be tar taped to reduce condensation. Re-bolt the black clamp to the roof beam. ****NOTE:** The copper lines coming out of the evaporator coil can be bent a bit, if required, for the best fit.
18. Once the A/C lines are secured and insulated at the evaporator, the two air ducts can be re-installed.
19. The drain pan requires four drain tubes to be connected to it. One to each front post and one to each side column. The front two tubes are feed down through the existing holes in the front cab posts. They slip over the front tubes on the drain pan and are secured in place with #6 gear clamps. At the bottom of the cab posts there is a rubber plug that must be cut out to accommodate the drain tube.

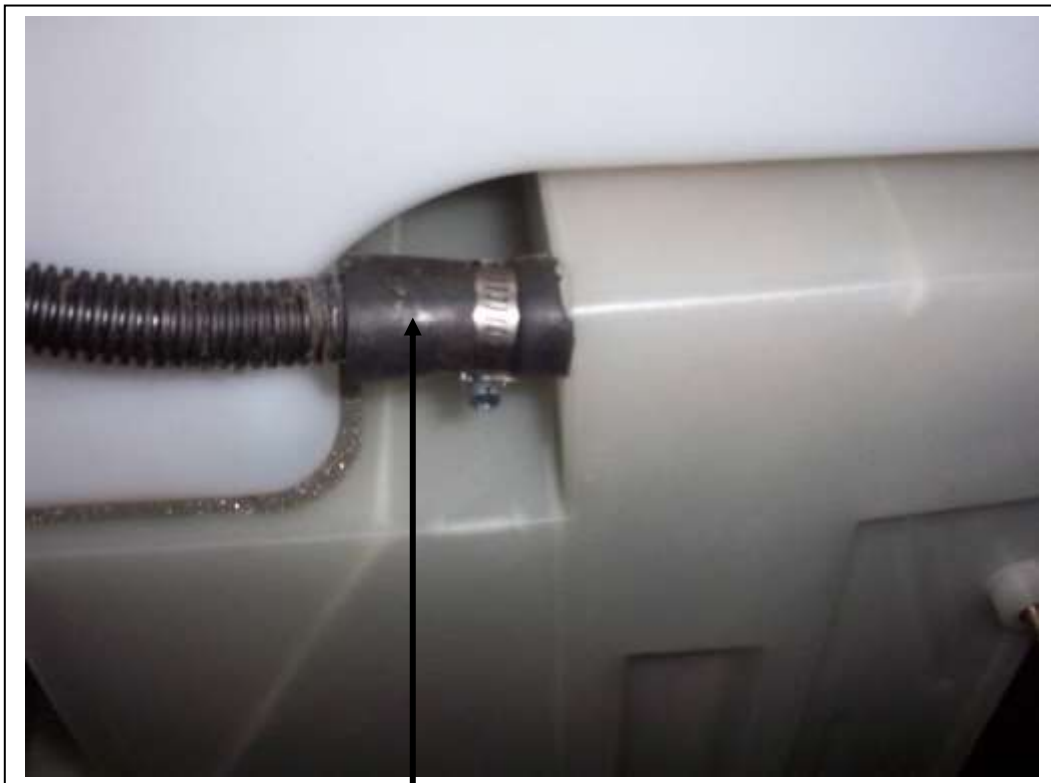

5/8” I.D. hose adapter on the end of the drain tube slides over the drain pan outlet and is secured with a #6 gear clamp.

20. The left rear drain hose slips over the tube on the left rear corner of the drain pan. It loops back to the left under the left air duct and down the left column. The tube is then routed forward over the front of the wheel well down to the hole in the floor just in front of the wheel well. The hole is covered by the floor mat and a plastic plug. There is a narrow channel built into the wheel well cover for the drain tube to run through. A wire snake may make this job easier.



Left rear drain tube

21. The right rear drain tube runs down the same column as the A/C hoses, but in front of the heater hoses. The hose makes a 90° to the right and then goes down the right column, under the electrical console and out the same hole in the floor that the A/C hoses pass through. Once the tube is run through the floor, any gaps in the floor can be plugged with tar tape or silicon. All four drain tubes need a 1/2" drain restrictor installed on the outlet end, outside the cab, using the #4 gear clamps provided.



Front right drain tube

Rear right drain tube

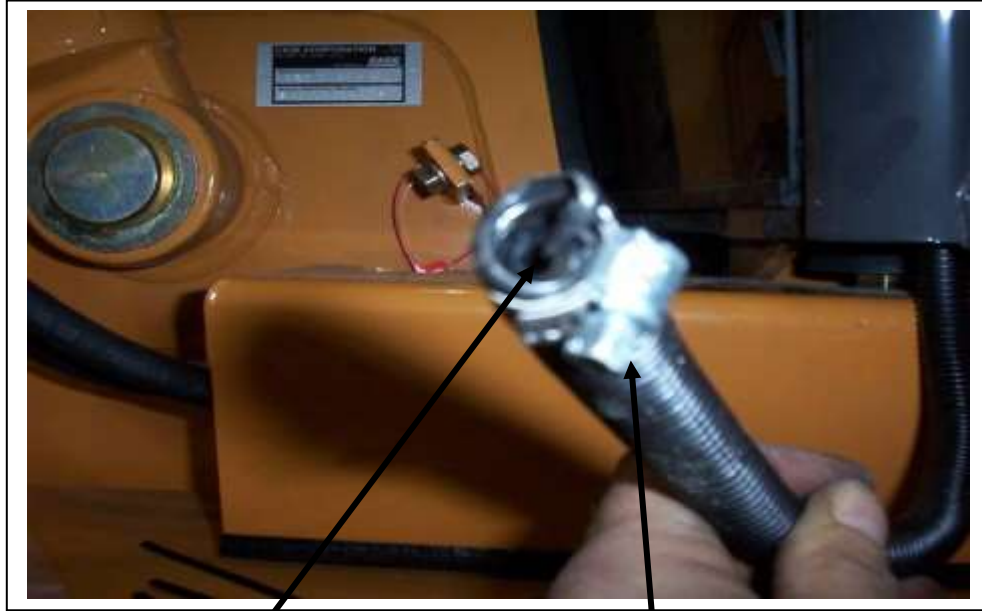

Drain tube restrictor

#4 gear clamp

22. Re-install the air filter shroud to the rear of the heater/evap box. Re-install the right lower louver air duct. Connect the two tie wraps together to make them long enough to fit around the duct. Connect the two flex ducts back up to the bottom of the air duct. Leave the headliner and side column covers off until the system has been fully tested. Re-install all components in the reverse order they were removed. Tie up the hoses under the electrical console so they don't interfere with any other parts.

COMPRESSOR:

- 1) Open the engine area to access the radiator fan and compressor area.

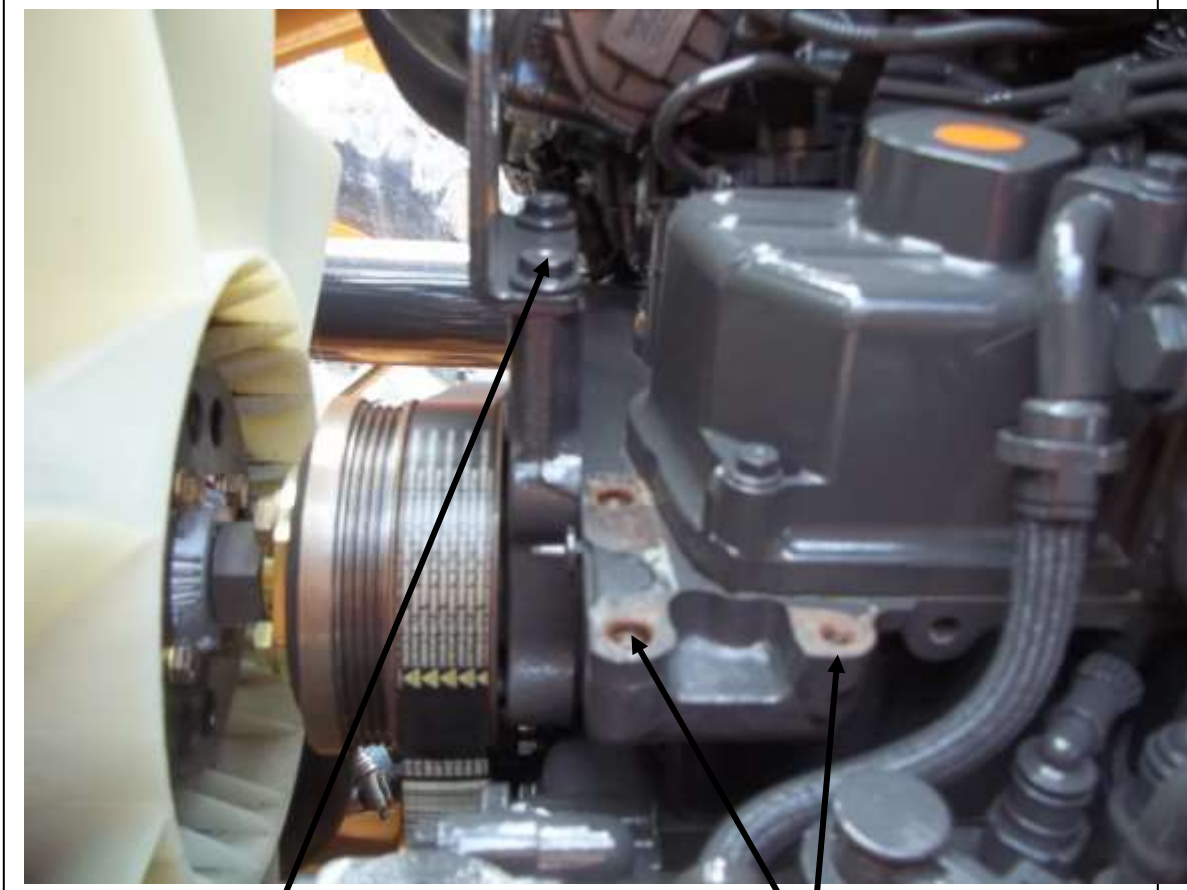

Remove these bolts and discard. The compressor mounts here. Re-use the engine lift bracket over the mount. New hardware in kit.

Compressor mount also bolts here with M8x80 mm bolts, washers and 1.89" spacers.

- 2) Compressor mount in place (on a different model) showing the spacers and the lifting bracket re-installed.



Compressor mount

1.89" long spacers



Remove the fan to install the AC belt. Re-install



#8 (13/32")
90° fitting
with r12
access port
for pressure
switch.

Install compressor as shown.

1/2" spacers and hardware
provided in kit.

#10 (1/2") 90° fitting
with R134a access port

Condenser:

- 1) Remove the grill and rubber bump pads from in front of the radiator.



Mount points for
condenser brackets.

Charge air cooler

Fuel cooler

Mount points
for condenser
brackets.

- 2) The condenser frames mount to four existing bolt holes in the charge air cooler that hold the fuel cooler.
- 3) Loosen all four bolts holding the fuel cooler to the charge air cooler. Only remove the upper two or lower two at a time to help keep both coolers in place.



Upper condenser frame.

The upper condenser bracket must be fitted into place as shown to slip the bracket past the outer radiator compartment frame. It will slide in low just overtop of the oil cooler.

- 4) Bolt the condenser brackets to the charge air cooler as shown. Start the threads of the M8x80MM bolt but leave them quite loose until all four bolts are started in both the upper and lower brackets. Tighten all bolts.



5/8" spacer

Fuel cooler bracket

M8x80mm bolt

9/16" spacer

Upper condenser bracket

Bolt and spacers
installed and
tightened in
place



The right hand side of the lower bracket has a shorter bar to fit under the fuel filter bracket.



Bottom left hand side of the bracket bolted in place. Note the extra metal extending above the bolt hole.



Lower condenser
bracket in place

Upper condenser
bracket in place

5) From the top of the charge air cooler, slide the condenser down between the fuel cooler and the charge air cooler. The condenser fittings go towards the bottom of the air cooler.



Lower condenser bracket

1/4" mounting bolts into existing threaded holes.

6) Bolt the condenser loosely to the lower condenser bracket using the 1/4" hardware provided

7) Secure the condenser to the upper bracket using the 1/4" hardware provided. Tighten all four bolts.



Upper condenser bracket

1/4" mounting bolts into existing threaded holes.

8) Connect the 5/16" and 13/32" fitting to the condenser as shown. Use the correct size "O" rings and oil the contact surfaces with PAG oil.



5/16" hose with 90° female fitting

Secure 13/32" hose to this bracket.

13/32 hose with straight female fitting with 134a access port.

- 9) When the installation is complete and tested reinstall the front grill and rubber bumpers.



Condenser and hoses in place

Drier: The receiver drier is mounted to the inside of the right hand front frame member behind the alternator and below the starter. The mount bracket is attached to an existing stud bolt that secures some hoses to the side of the frame member.

Steps:

1. Remove the nut and washer from the stud bolt located ahead of the cab and behind the alternator on the inside of the right hand front frame member.

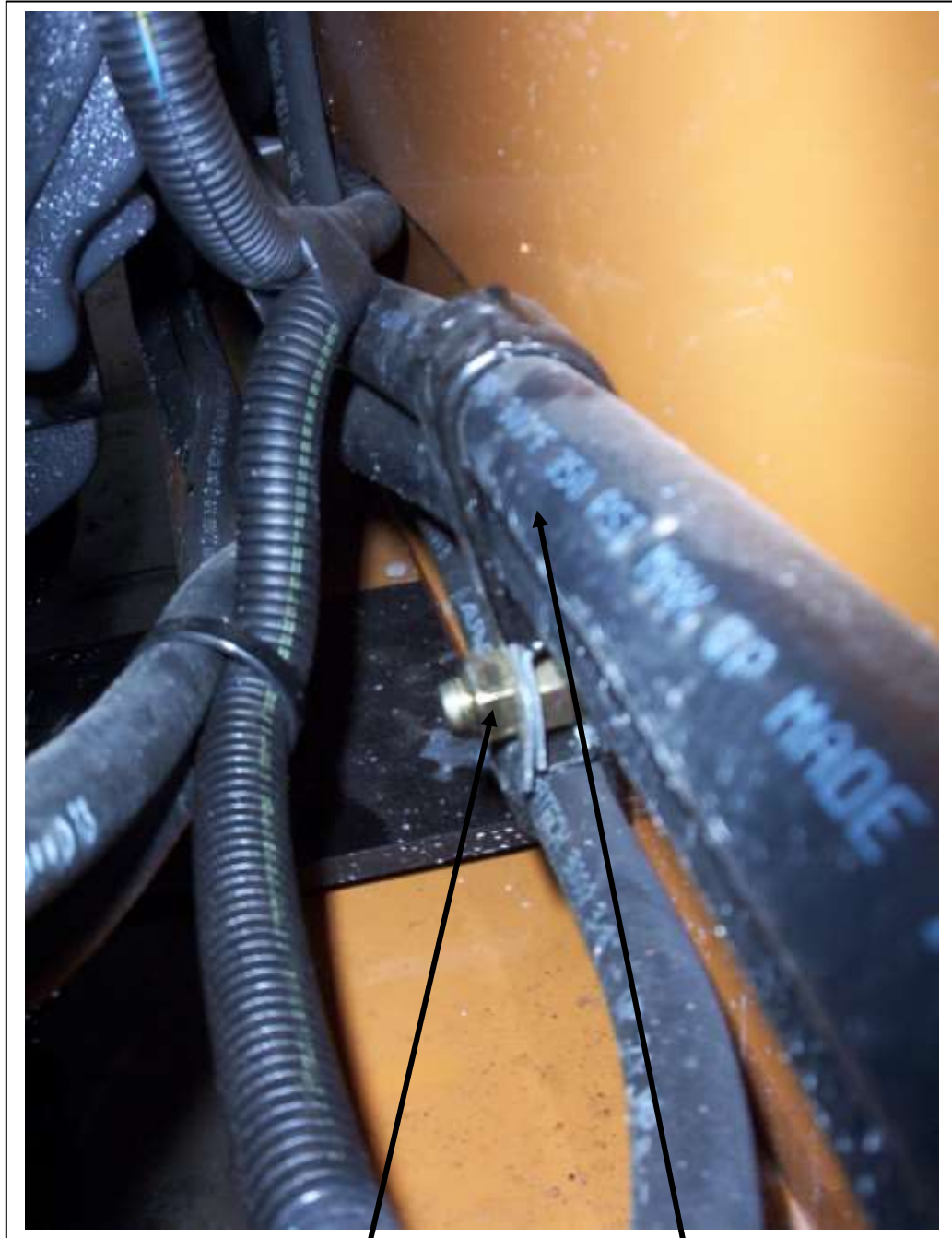

Stud bolt and nut

Heater hoses and clamp in their original position.

2. Mount the drier bracket on the bolt holding the heater hose clamp in place. The drier bracket will hang below the heater hoses.



Drier bracket in place.

3. Install the straight drier bracket so it points as shown. Re-install the washer and nut to secure the bracket in place.



#48 gear clamps

5/16" 90° fitting on the drier inlet.

4. Clamp the drier to the bracket using the #48 gear clamps provided. Position the inlet of the drier towards the front of the machine. It is marked with an “IN” stamped on the inlet.

HOSE RUNS:

The hoses are all pre-crimped and pressure tested for leaks.

13/32" Hose Compressor to Condenser:

The hose runs from the compressor fitting (the 90° fitting with the ¼" service access port) to the straight fitting on the bottom of the condenser. The hose is routed back toward the cab from the compressor down, around and forward under the radiator and across the front of the condenser and up to the top fitting on the coil. The straight fitting with the R134a access port connects condenser. See the pictures for the condenser installation above.

5/16" Hose Condenser to Drier:

The hose runs from the condenser outlet fitting (bottom) to the drier along the right hand side of the engine. Connect the 90° fitting to the condenser and loop the hose down under the radiator and out along the frame on the right side of the machine. Follow the 13/32" hose to the drier. Connect the other fitting to the 'INLET' fitting on the drier.

5/16" Hose Drier to Evaporator:

The hose runs from the drier along the side of the frame and up into the cab on the right side of the operator. The hose is run into the cab with the ½" suction line from the compressor. Run both the lines up the right side column (behind the cover and brackets) and to the evaporator expansion valve.

1/2" Hose Evaporator to Compressor:

The ½" hose is first connected at the compressor using the 90° fitting with the R134a access port. Connect this fitting to the compressor fitting and run the hose back as shown. The hose will cross over to the right side of the machine under the cab and behind the engine. It then follows the 5/16" hose into the cab and up to the evaporator. Connect the 45° fitting at this end to the evaporator outlet fitting.

ELECTRICAL: The electrical system for the Air Conditioning takes power off the clutch terminal of the blower switch. This is the terminal that is live when the blower fans are running. Take power from this terminal and run to the thermostat. The thermostat is mounted in the same console as the blower switch and other controls, and is in the factory location. From the thermostat run the black 14ga clutch wire in the split loom out of the cab with the hoses. Run forward with the 1/2" hose to the compressor and connect to the pressure switch on the high side fitting. Connect to the clutch wire running out of the compressor.

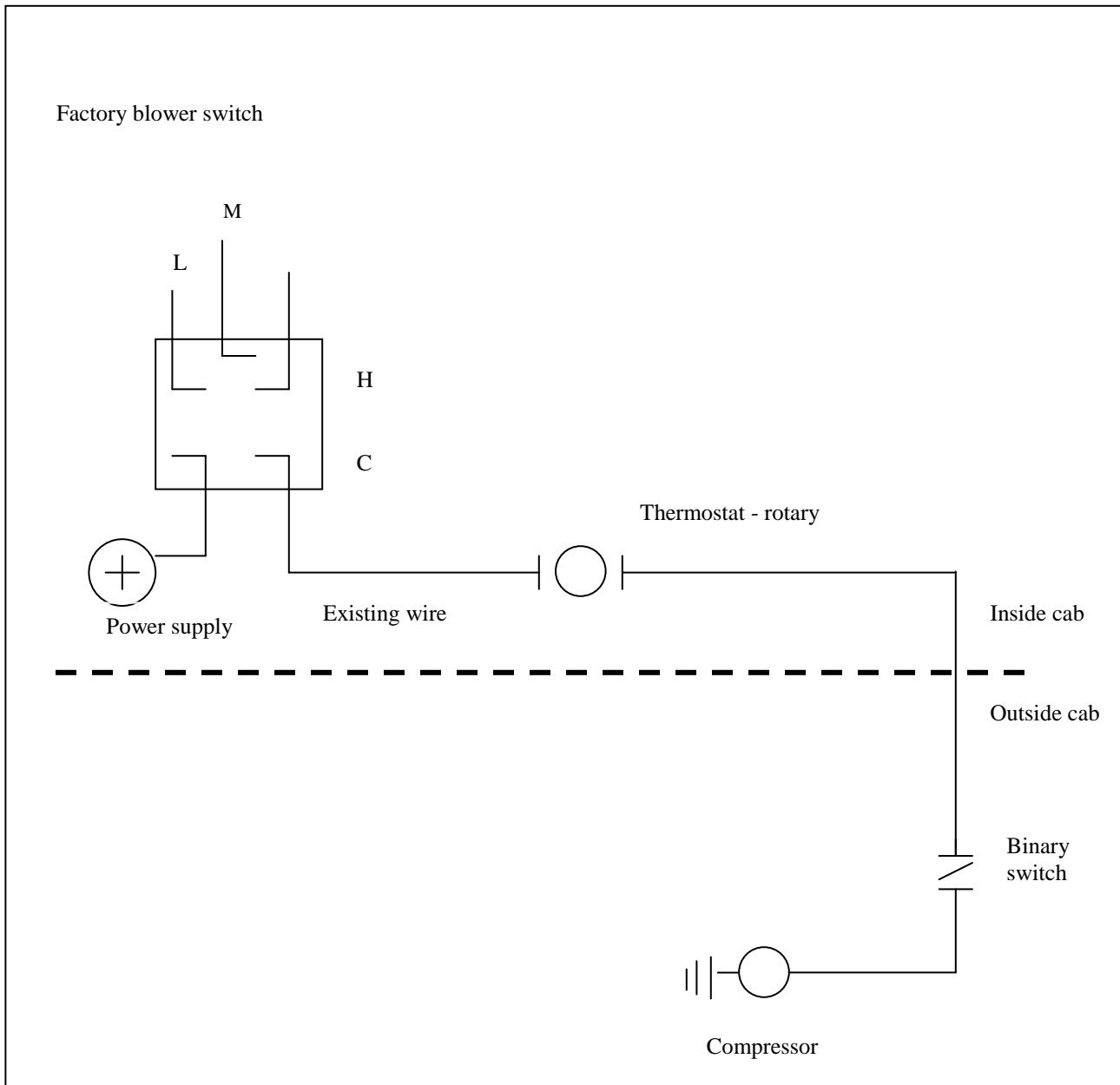

CHARGING AND TESTING

- 1) Pressure test the system using nitrogen to a pressure of 250 psi. Check for leaks.
- 2) Add 2oz of SP20 Sanden PAG oil to the system.
- 3) Vacuum the system for at least ½ hour.
- 4) Check that the vacuum holds.
- 5) Fill the system with 2.75 to 3 lbs of R134a refrigerant. **DO NOT USE ANY OTHER TYPE OF REFRIGERANT OR IT WILL VOID THE WARRANTY.**
- 6) Test the system. Check the cycling temperature of the thermostat. Adjust the thermostat settings if required to avoid coil freeze up problems. See the thermostat setting procedures at the end of these instructions.

Refrigerant Flow Pattern in a Standard Air Conditioning System

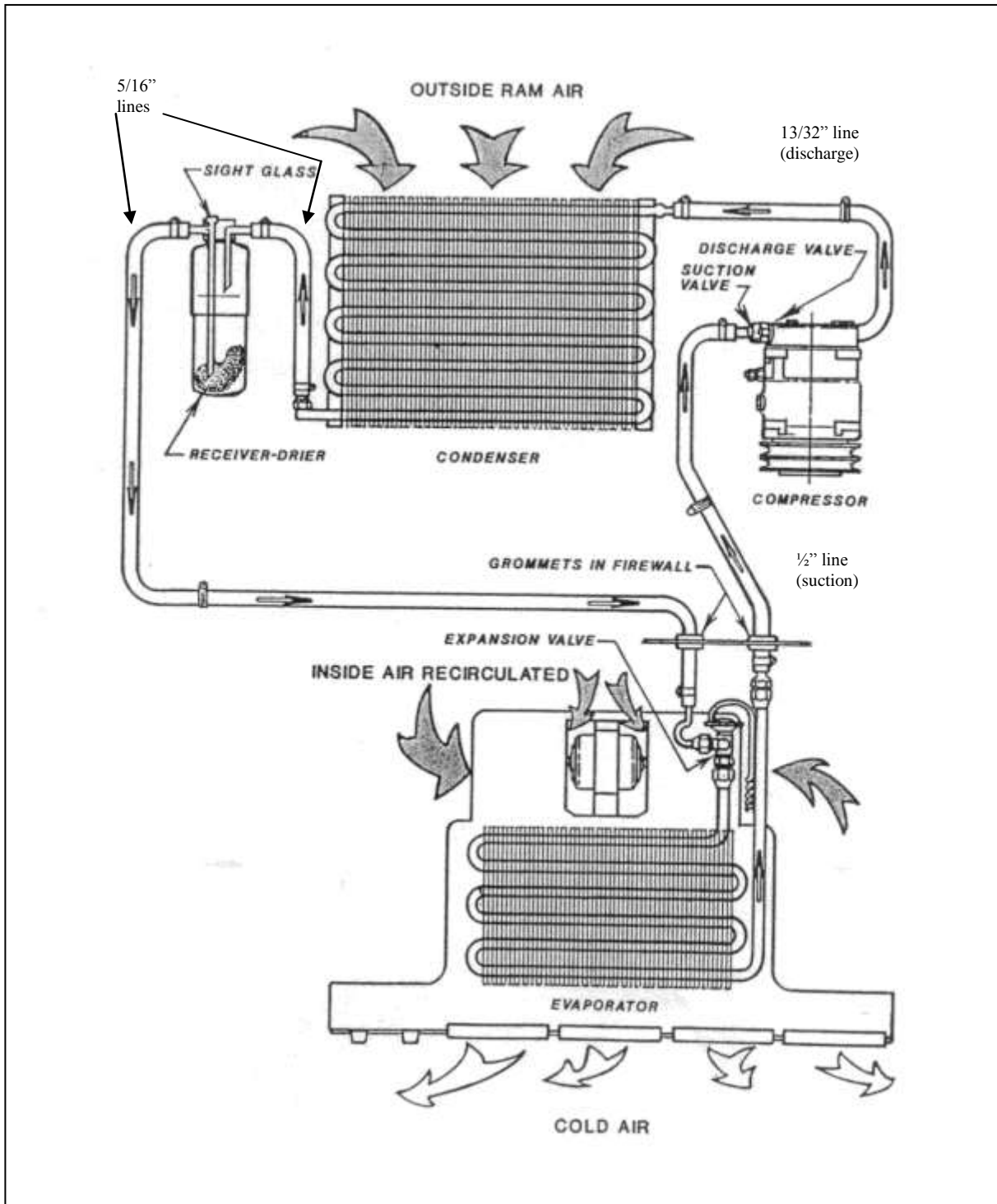

Thermostat Setting Procedures

- 1) Thermostat types
 - a) preset
 - b) adjustable
 - a) A preset thermostat is adjusted to its specific cut in and cut out temperatures when manufactured and does not have a rotary adjustment for the operator.
 - b) An adjustable or rotary thermostat has been manufactured to a predetermined cut in and cut out temperatures, but it is also operator adjustable to achieve the desired comfort level.

Both types of thermostats can have their factory settings adjusted by turning the setting screws on the body of the thermostat. One body type has the setting screws mounted externally and labeled for direction of rotation. The other body type requires the removal of the plastic end plate to expose the set screw.

- 2) Thermostat probe location: The location of the thermostat probe in an evaporator coil can be very important to achieve the maximum cooling potential of the coil while also preventing coil freeze-up. There is no set location for the thermostat probe to be put that will be optimum for all systems, but several rules of thumb may be followed:
 - a) Insert the probe in the coldest area of the evaporator coil.
 - b) Insert the probe from the top of the coil down, if possible.
 - c) Make sure that at least the last 3" of the thermostat probe are in the coil.

To find the most likely area where the coil is the coldest, consider these factors:

- 1) Direction of air flow through the coil.
 - 2) The coil area likely to have the lowest air flow.
 - 3) The inlet locations of the refrigerant into the coil.
 - 4) The inlet of the hotter outside air into the coil area.
-
- 1) Usually the coldest side of the evaporator coil will be the air outlet side. Often the thermostat probe can be inserted between the last and second last row of tubes.
 - 2) The lower air flow area of the evaporator coil in most systems tends to be near either end of the coil. These areas will be colder
 - 3) The area of the coil that the refrigerant inlet tube(s) occupy should be the coldest part of the coil.
 - 4) If the system is equipped with an outside air intake, where and how that air is brought into the evaporator area can have a large effect on the coil temperature. If all the outside air is piped into the evaporator in one area, that area will be considerably warmer in hot weather.

By looking at all these different factors, the area of an evaporator coil most likely to be the coldest can be determined.

Once the probe is inserted, the A/C system needs to be tested. Run the system to ensure that the thermostat is cycling the compressor off at the appropriate temperature. A core temperature ranging between 25° and 30° F should cause the thermostat to cycle off. The air temperature at the vent outlet closest to the evaporator coil should be between 38° F and 45° F when the compressor cycles off.

If the thermostat doesn't cycle off after a reasonable cool down period, and the air outlet temperature has dropped below 40° F, the cut in and cut out settings should be adjusted until the compressor is cycling on and off regularly. Let the system run for a decent time period (at least 15 min) and then check the evaporator coil for any signs of freezing.

Aeroquip E-Z Clip Assembly Instructions

Step 1. Cut the hose to proper length with an appropriate cutting tool. Aeroquip's hand held hose cutter has been specially designed for cutting all non-wire reinforced hose, such as GH-134 Multi-Refrigerant hose. Be sure the cut is made square to the hose length.

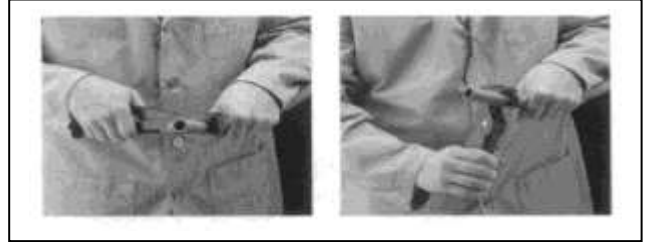

Step 2. Install two proper-sized clips onto the cut end of the hose. Orientation of the clips does not affect the performance of the connection. However, for ease of assembly, both clips should have the same orientation. NOTE: Failure to slide the clips over the hose at this time will require the clips to be stretched over the hose or fitting later. This may permanently damage the clip.



Step 3. Lubricate the nipple with a generous amount of the refrigeration or A/C system's compressor lubricating oil. This MUST be done to lower the force of nipple insertion.

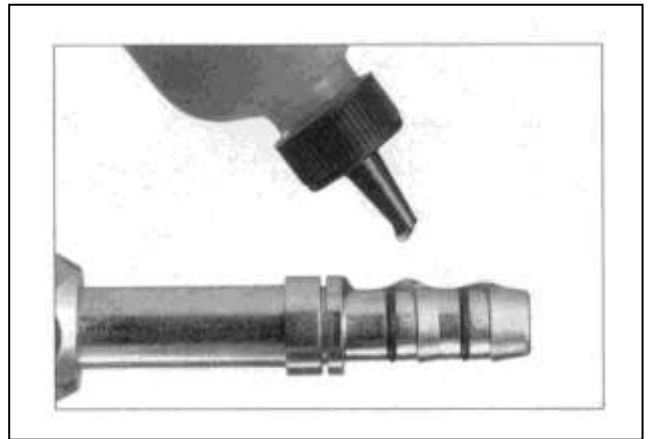

Step 4. Insert the nipple into the hose. To ensure that the nipple is fully inserted, check the gap between the cut end of the hose and the shoulder on the nipple. Care should be taken to avoid kinking or other damage to the hose during nipple insertion. NOTE: Be sure to wipe excess oil from the nipple and hose.



Step 5. Snap the cage into the groove on the nipple. The arms should extend over the hose length. When the cage has been correctly installed in the cage groove, the cage will be able to rotate in the groove. This step **MUST** be performed to ensure:

1. The clips will be located over the O-rings on the nipple.
2. The connection will be compatible with the connection's pressure rating.

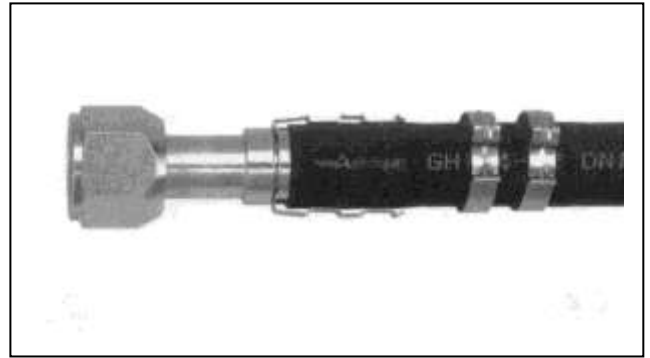

Step 6. Slide the clips over the cage arms and into the channels on each arm.



Step 7. Use the pliers to close the clips. The pliers should be positioned squarely on the clip connection points and should remain square during the closing of the clip.

NOTICE: E-Z Clip components should not be reused.

